



# QUALITY FILTERS, INC.

THINKSIMPLE. THINKSMART. THINKQUALITY.

23351 Grissom Drive  
Robertsdale, AL 36567  
www.QualityFilters.com

Phone: (251) 947-2400  
Order Fax: (251) 947-2499  
Sales Fax: (251) 947-7948

## QUALITY SEAL - 2" Tackified Media Multi-Pocket Polyester Cube Filters

Date 24 Aug 09	Dwg No.	Rev
Date 24 Aug 09	<b>Q-110007</b>	<b>B</b>

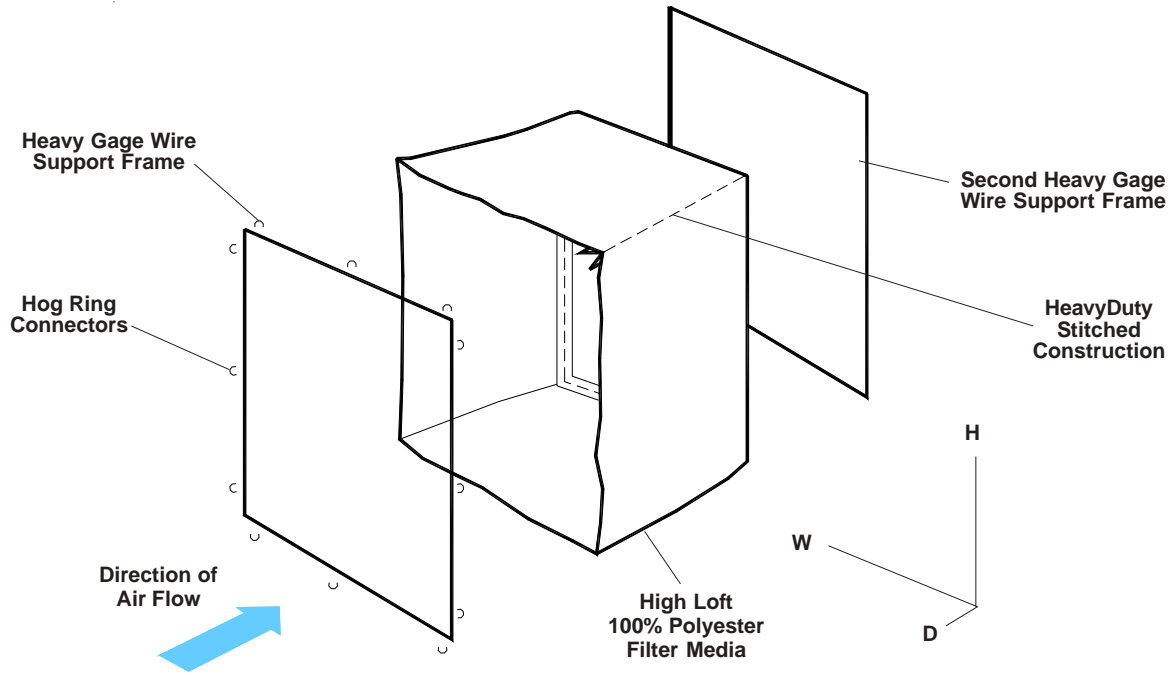

1 Pocket Configuration Shown

**Notes:**

Quality Seal Multi-Pocket Polyester Cube Filters offer up to five times the filter area of flat panels. One, Two, and Three pocket configurations in any media or combination of medias are available. Quality Seal Multi-Pocket Polyester Cube Filters are the best way to maximize the service life and efficiency of the "Quality Seal" polyester medias. Double wire frame construction encapsulates the media, providing a self sealing support that also withstands warping from heavy loading and aggressive installation. Polyester overlap around the edges inhibits dust and paint bypass. Ideal for HVAC or Paint Overspray collection. Aerospace systems are available.

**Part Number Guide**

Product Code	Pocket Count*	Media	Dimensions	Header	No Support Wire
CF	1	2" Tackified	WxHxD	H	X

**Examples:**  
 CF12T122412 = Cube Filter, 1 Pkt, 2" Tackified Media, 12x24x12  
 CF32T202015H = Cube Filter, 3 Pkt, 2" Tackified Media, 20x20x15, with Header  
 \*Q denotes 2 triangle shaped pockets

**Typical Performance Data (24x24x15 - 1 Pocket Filter)**

Product Code	ASHRAE 52.2 - 1999				Initial Resistance "w.g."	Final Resistance "w.g."
	MERV Value	E1 %	E2 %	E3 %	@ 300 fpm	@ 300 fpm
CF12T	< 5	n/a	n/a	n/a	0.03	1.00

**Media Area (sq. ft.) 2" Tackified Media**

Face Dimensions	1 Pkt Square Cubes			2 Pkt Tapered Cubes		
	Depth	12"	15"	20"	12"	15"
12x24	8.00	9.50	12.0	-	-	-
16x20	8.22	9.72	12.22	8.67	10.83	14.44
16x25	9.61	11.32	14.17	10.33	12.92	17.22
20x20	9.44	11.11	13.89	9.17	11.46	15.28
20x24	10.67	12.50	15.56	10.50	13.13	17.50
20x25	10.97	12.85	15.97	10.83	13.54	18.06
24x24	12.00	14.00	17.33	11.00	13.75	18.33
Face Dimensions	2 Pkt Triangular Cubes			3 Pkt Tapered Cubes		
	Depth	13"	14"	16"	18"	12"
12x24	6.71	-	-	-	-	-
20x20		7.86	-	-	13.75	17.19
20x25			10.0	-	16.25	20.31
24x24				11.31	16.50	20.63

Characteristics	Quality Seal Multi-Pocket 2" Tackified Cube Filters
Filter Media	2" thick; 6, 15, and 40 denier polyester blend with a non-migrating dry tackified downstream surface
Construction Technique	Sewn pockets with hog ring fasteners
Support Frames	Two 0.148 inch (9 gage) galvanized steel wire frames
Max. Temperature	100°F (38°C) continuous service, Peaks 120°F (49°C)
Max. Humidity	Resistant to 100% R.H.